

CX-04 VISTA GERAL
ESCALA 1:20

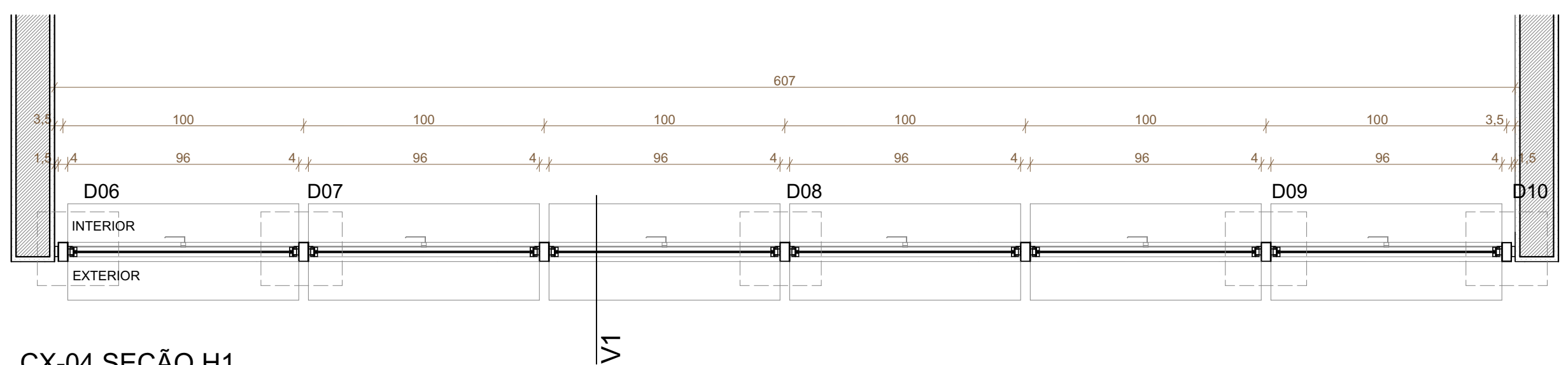

CX-04 SEÇÃO H1
ESCALA 1:20

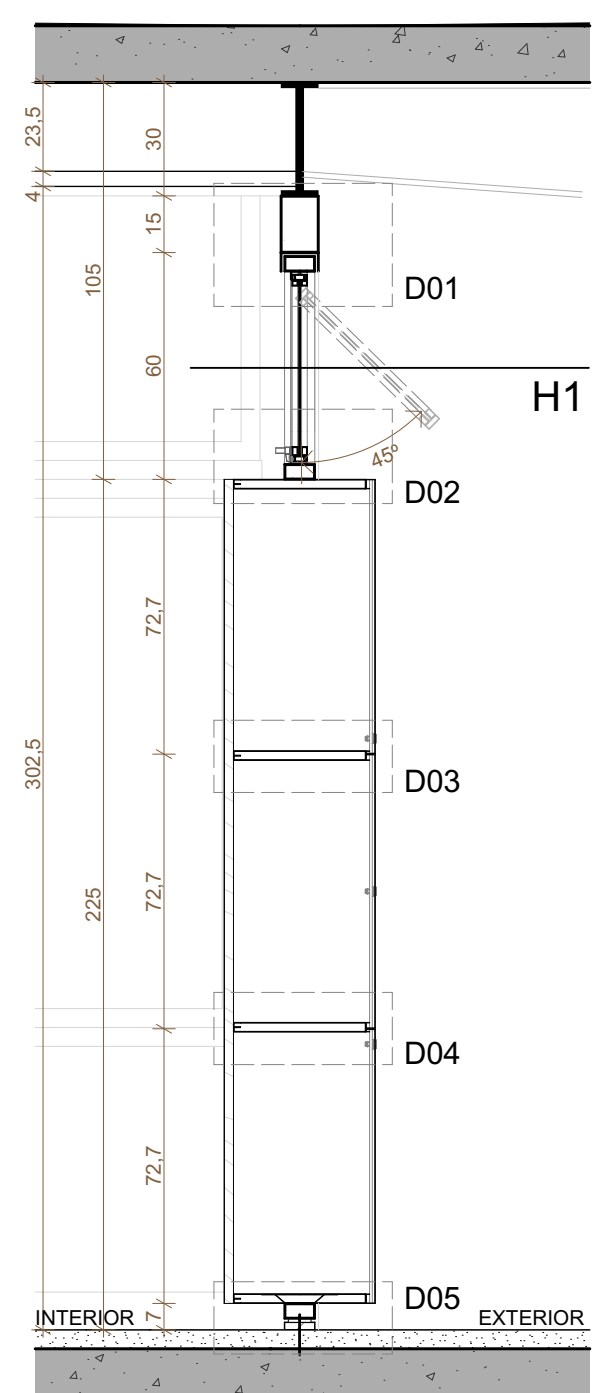

CX-04 SEÇÃO V1
ESCALA 1:20

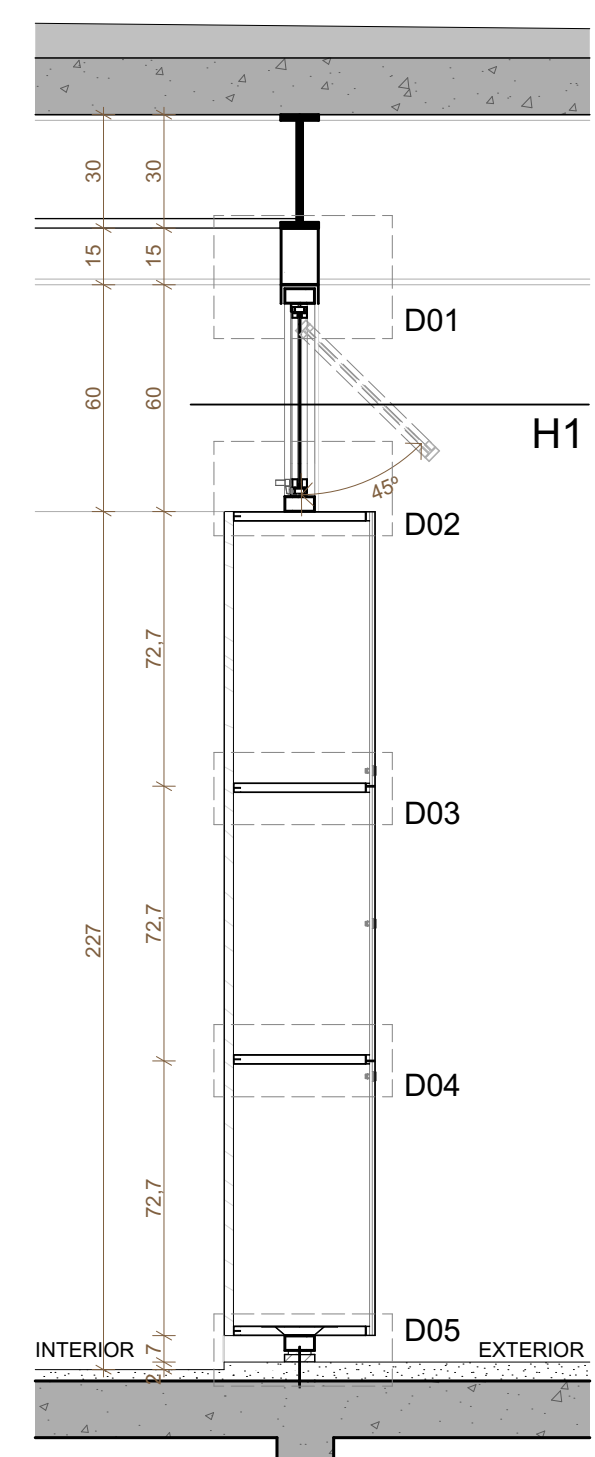

CX-05 SEÇÃO V1
ESCALA 1:20

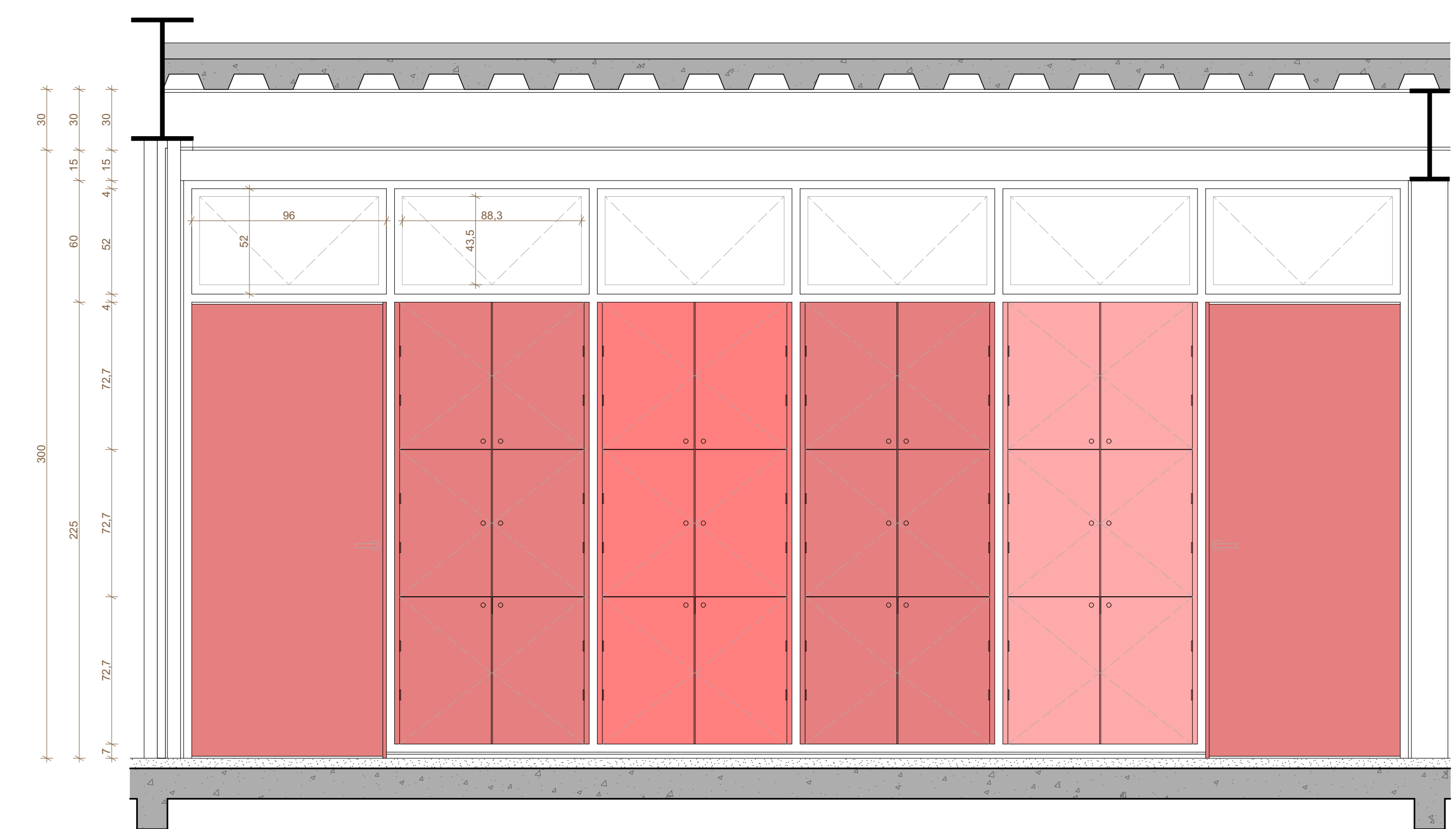

CX-05 VISTA GERAL
ESCALA 1:20

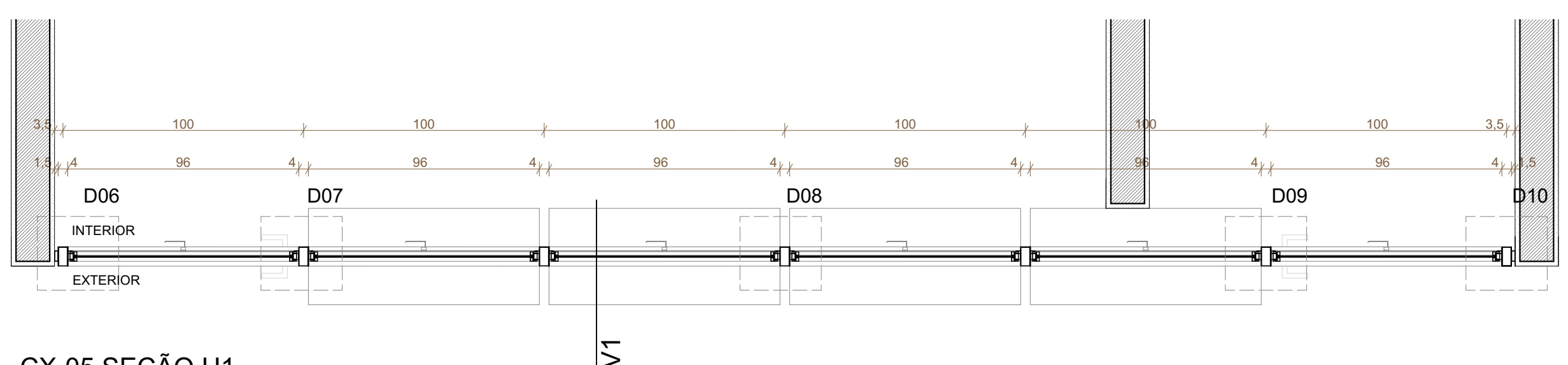

CX-05 SEÇÃO H1
ESCALA 1:20

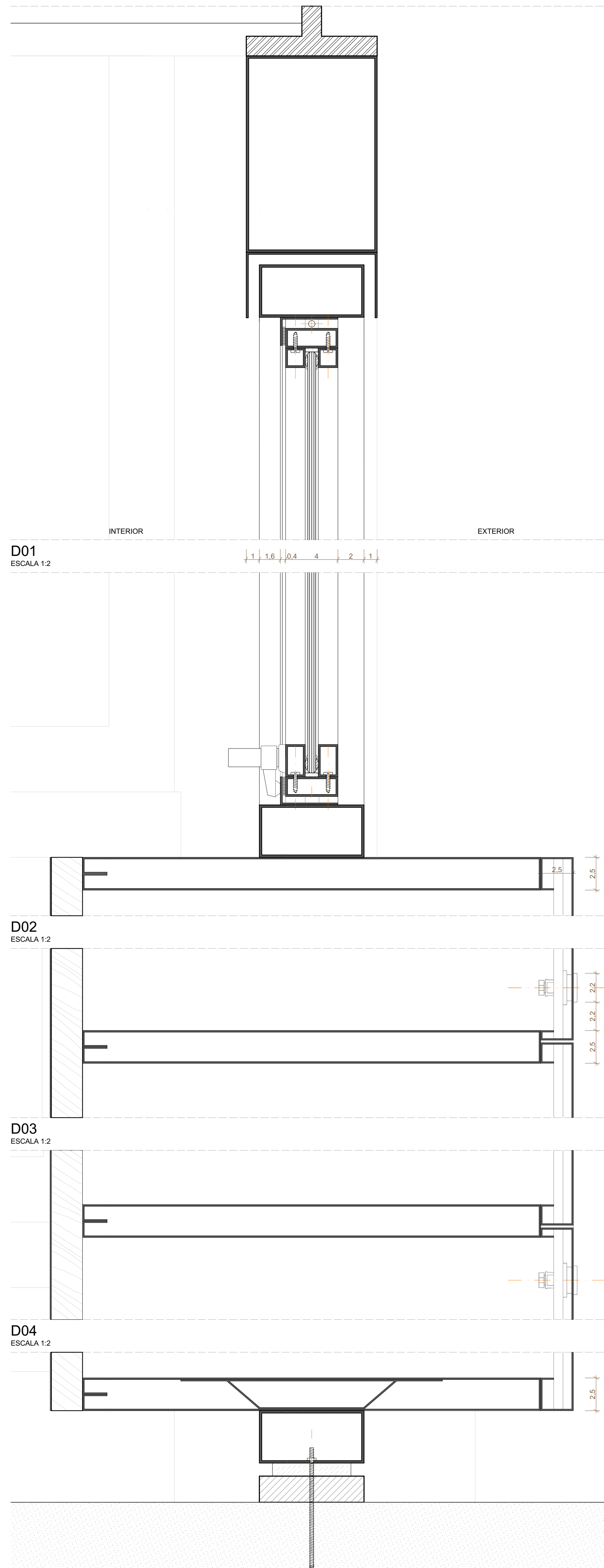

D01
ESCALA 1:2

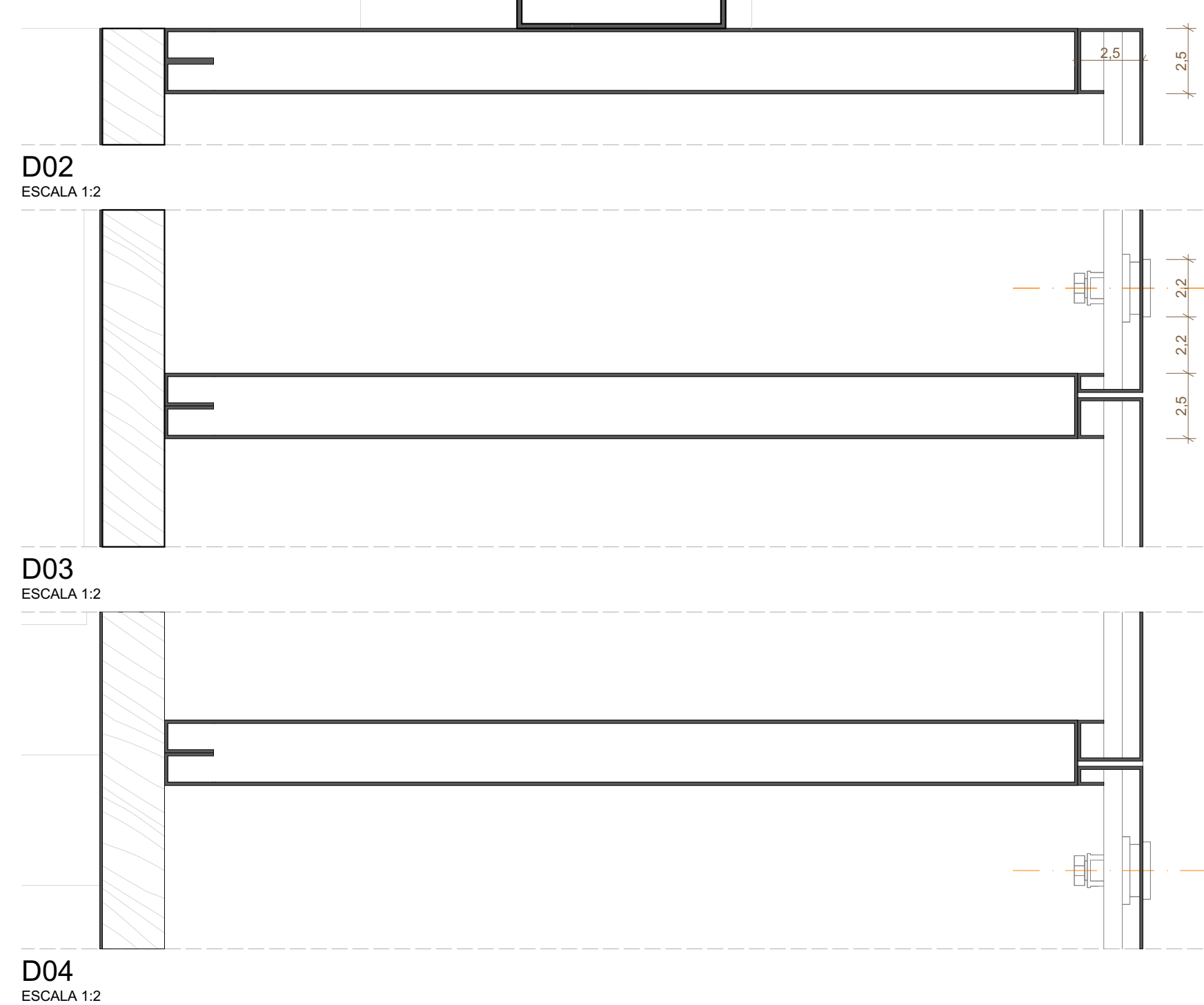

D02
ESCALA 1:2

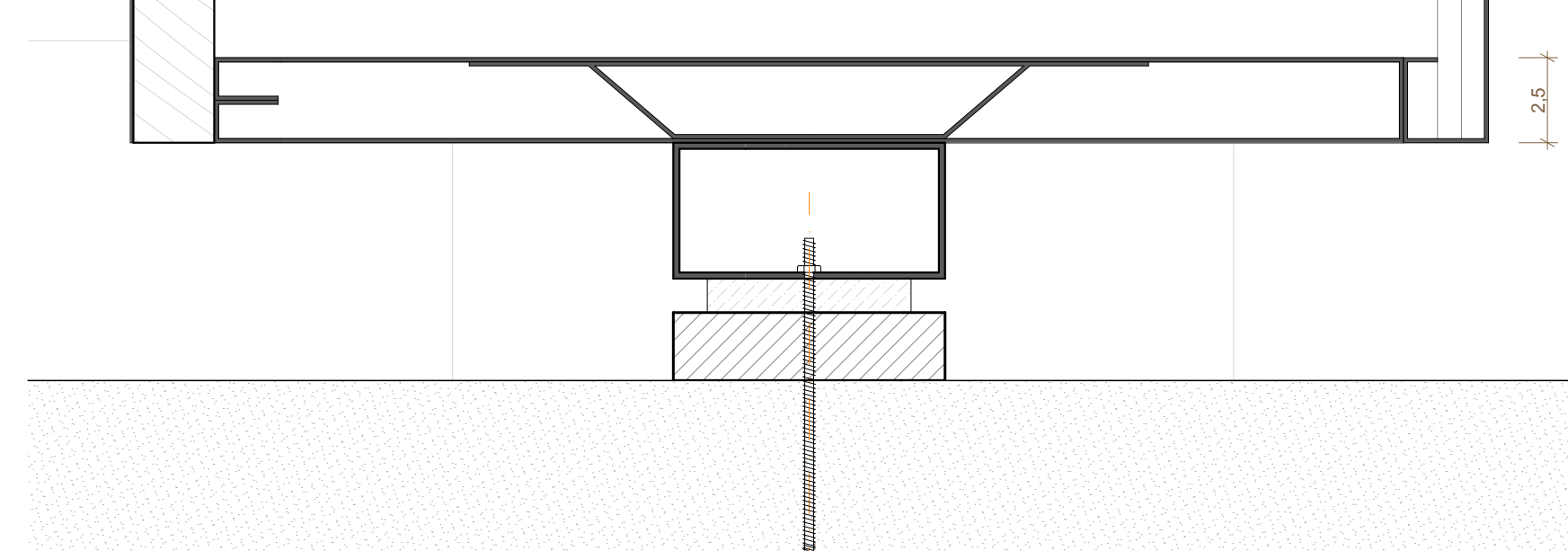

D03
ESCALA 1:2

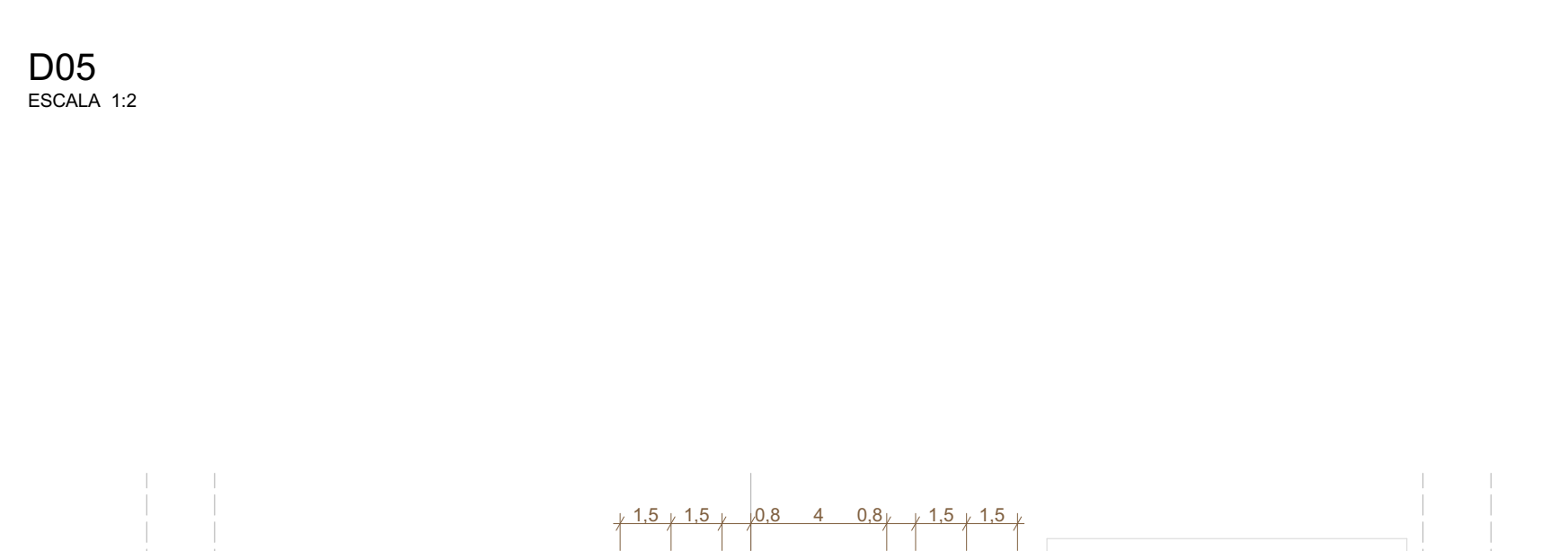

D04
ESCALA 1:2

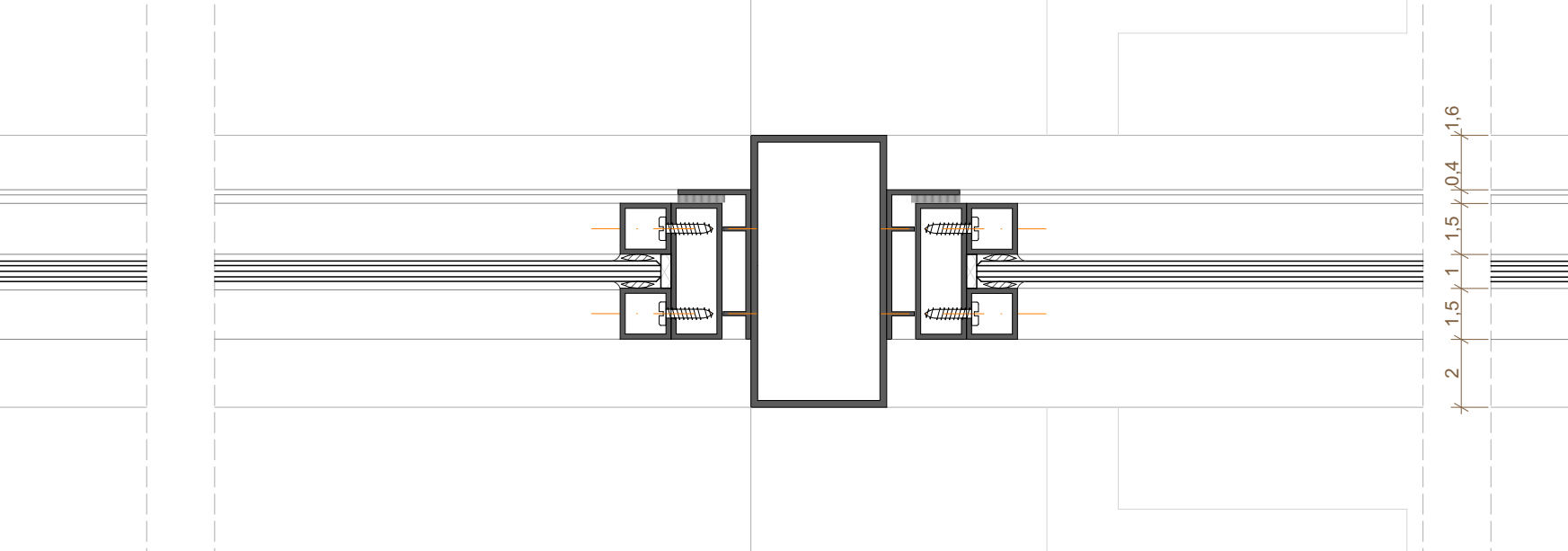

D05
ESCALA 1:2

- 1 - PERFIL INDUSTRIAL 100X150MM
- 2 - CHAPA DOBRADA 50X100MM
- 3 - PERFIL INDUSTRIAL 40X60MM
- 4 - CHAPA DOBRADA 21,5X44MM
- 5 - PERFIL INDUSTRIAL 40X15MM
- 6 - BAGUETE METÁLICO 15X15MM
- 7 - VIDRO TEMPERADO 6MM
- 8 - CONJUNTO DE FIXAÇÃO DOS VIDROS EM ESPUMA P.E.C.F., TARUCEL P.E. E SILICONE NEUTRO
- 9 - MAÇANETA DE JANELA BASCULANTE
- 10 - BAGUETE METÁLICO 25X15MM
- 11 - PARAFUSO
- 12 - CHAPA DE AÇO DOBRADA (E=1,2MM) DE ESTRUTURAÇÃO DOS ARMÁRIOS
- 13 - CHAPA DE AÇO DOBRADA (E=1,2MM) DE FECHAMENTO E ESTRUTURAÇÃO DAS PORTAS DOS ARMÁRIOS
- 14 - PAINEL EM MADEIRA COMPENSADA DE FUNDO DO ARMÁRIO
- 15 - FECHADURA DO ARMÁRIO
- 16 - CHAPA DE AÇO DOBRADA (E=1,2MM) DE FECHAMENTO DO FUNDO DO ARMÁRIO
- 17 - CHAPA DE REFORÇO E FIXAÇÃO (E=1,2MM) DOS ARMÁRIOS NA BASE DE GRANITO
- 18 - BORRACHA
- 19 - BASE DE GRANITO 80X20MM
- 20 - EIXO ROSQUEÁVEL EM AÇO - FIXAÇÃO ATÉ ALAJE
- 21 - PERFIL INDUSTRIAL 44X15MM
- 22 - PERFIL INDUSTRIAL MONTANTE 80X40MM

VIDROS: TODAS AS ESQUADRIAS COM VIDROS VOLTADOS PARA O EXTERIOR E/OU ABAIXO DE 90CM DE ALTURA TERÃO VIDROS DE SEGURANÇA (LAMINADO OU ARAMADO).

ESPECIFICAÇÃO ARMÁRIOS: PINTURA COM TINTA ESMALTE PREMIUM COM ACABAMENTO FOSCO PARA METAIS COR VERMELHO ESCURO, REF. SUVINIL ESMALTE COR E PROTEÇÃO COR GOIABADA (R243, PG.43) OU SIMILAR.

PINTURA COM TINTA ESMALTE PREMIUM COM ACABAMENTO FOSCO PARA METAIS COR VERMELHO ESCURO, REF. SUVINIL ESMALTE COR E PROTEÇÃO COR GOIABADA (R243, PG.43) OU SIMILAR.

PINTURA COM TINTA ESMALTE PREMIUM COM ACABAMENTO FOSCO PARA METAIS COR VERMELHO ESCURO, REF. SUVINIL ESMALTE COR E PROTEÇÃO COR SAIA JUSTA (D107, PG.43) OU SIMILAR.

ESPECIFICAÇÃO ESQUADRIAS: CAIXILHOS EM AÇO COM ACABAMENTO EM PINTURA COM TINTA ESMALTE SINTÉTICO SOBRE FUNDO ANTIOXIDANTE COM ACABAMENTO FOSCO PARA METAIS COR CINZA, REF. SUVINIL ESMALTE COR E PROTEÇÃO COR NIQUEL (C370, PG. 170) OU SIMILAR. VEDAÇÃO EM VIDRO TEMPERADO INCOLOR 6MM.

REVISÃO	DATA	DESCRIÇÃO
R00	02/12/2019	EMISSÃO INICIAL

- NOTAS:
- 1 - NÃO MEDIR O DESENHO, SEMPRE CONSIDERAR AS COTAS.
 - 2 - COTAS EM METROS, NUNCA EM MILÍMETROS. TODA COTA INDICADA DEVERÁ SER CONFIRMADA NA OBRA.
 - 3 - EM CASO DE INCONFÉRIÊNCIA ENTRE DESENHOS, A ESCALA MAIS AMPLA É A QUE VIGORAR.
 - 4 - EM CASO DE DÚVIDA, O RESPONSÁVEL TÉCNICO DEVERÁ SER CONSULTADO.
 - 5 - TODOS OS DETALHES SEMPRE SERÃO MODIFICADOS PELA CONSTRUTORA MEDIANTE EXECUÇÃO DE PROTÓTIPO E APROVAÇÃO PRÉVIA DO ARQUITETO RESPONSÁVEL E DO CLIENTE.
 - 6 - OBSERVAR AS NORMAS DE ACESSIBILIDADE VIGENTES (NBR 9070, 9076, 9078, 9079, 9080, 9081, 9082, 9083, 9084, 9085, 9086, 9087, 9088, 9089, 9090, 9091, 9092, 9093, 9094, 9095, 9096, 9097, 9098, 9099, 9100, 9101, 9102, 9103, 9104, 9105, 9106, 9107, 9108, 9109, 9110, 9111, 9112, 9113, 9114, 9115, 9116, 9117, 9118, 9119, 9120, 9121, 9122, 9123, 9124, 9125, 9126, 9127, 9128, 9129, 9130, 9131, 9132, 9133, 9134, 9135, 9136, 9137, 9138, 9139, 9140, 9141, 9142, 9143, 9144, 9145, 9146, 9147, 9148, 9149, 9150, 9151, 9152, 9153, 9154, 9155, 9156, 9157, 9158, 9159, 9160, 9161, 9162, 9163, 9164, 9165, 9166, 9167, 9168, 9169, 9170, 9171, 9172, 9173, 9174, 9175, 9176, 9177, 9178, 9179, 9180, 9181, 9182, 9183, 9184, 9185, 9186, 9187, 9188, 9189, 9190, 9191, 9192, 9193, 9194, 9195, 9196, 9197, 9198, 9199, 9200, 9201, 9202, 9203, 9204, 9205, 9206, 9207, 9208, 9209, 9210, 9211, 9212, 9213, 9214, 9215, 9216, 9217, 9218, 9219, 9220, 9221, 9222, 9223, 9224, 9225, 9226, 9227, 9228, 9229, 9230, 9231, 9232, 9233, 9234, 9235, 9236, 9237, 9238, 9239, 9240, 9241, 9242, 9243, 9244, 9245, 9246, 9247, 9248, 9249, 9250, 9251, 9252, 9253, 9254, 9255, 9256, 9257, 9258, 9259, 9260, 9261, 9262, 9263, 9264, 9265, 9266, 9267, 9268, 9269, 9270, 9271, 9272, 9273, 9274, 9275, 9276, 9277, 9278, 9279, 9280, 9281, 9282, 9283, 9284, 9285, 9286, 9287, 9288, 9289, 9290, 9291, 9292, 9293, 9294, 9295, 9296, 9297, 9298, 9299, 9300, 9301, 9302, 9303, 9304, 9305, 9306, 9307, 9308, 9309, 9310, 9311, 9312, 9313, 9314, 9315, 9316, 9317, 9318, 9319, 9320, 9321, 9322, 9323, 9324, 9325, 9326, 9327, 9328, 9329, 9330, 9331, 9332, 9333, 9334, 9335, 9336, 9337, 9338, 9339, 9340, 9341, 9342, 9343, 9344, 9345, 9346, 9347, 9348, 9349, 9350, 9351, 9352, 9353, 9354, 9355, 9356, 9357, 9358, 9359, 9360, 9361, 9362, 9363, 9364, 9365, 9366, 9367, 9368, 9369, 9370, 9371, 9372, 9373, 9374, 9375, 9376, 9377, 9378, 9379, 9380, 9381, 9382, 9383, 9384, 9385, 9386, 9387, 9388, 9389, 9390, 9391, 9392, 9393, 9394, 9395, 9396, 9397, 9398, 9399, 9400, 9401, 9402, 9403, 9404, 9405, 9406, 9407, 9408, 9409, 9410, 9411, 9412, 9413, 9414, 9415, 9416, 9417, 9418, 9419, 9420, 9421, 9422, 9423, 9424, 9425, 9426, 9427, 9428, 9429, 9430, 9431, 9432, 9433, 9434, 9435, 9436, 9437, 9438, 9439, 9440, 9441, 9442, 9443, 9444, 9445, 9446, 9447, 9448, 9449, 9450, 9451, 9452, 9453, 9454, 9455, 9456, 9457, 9458, 9459, 9460, 9461, 9462, 9463, 9464, 9465, 9466, 9467, 9468, 9469, 9470, 9471, 9472, 9473, 9474, 9475, 9476, 9477, 9478, 9479, 9480, 9481, 9482, 9483, 9484, 9485, 9486, 9487, 9488, 9489, 9490, 9491, 9492, 9493, 9494, 9495, 9496, 9497, 9498, 9499, 9500, 9501, 9502, 9503, 9504, 9505, 9506, 9507, 9508, 9509, 9510, 9511, 9512, 9513, 9514, 9515, 9516, 9517, 9518, 9519, 9520, 9521, 9522, 9523, 9524, 9525, 9526, 9527, 9528, 9529, 9530, 9531, 9532, 9533, 9534, 9535, 9536, 9537, 9538, 9539, 9540, 9541, 9542, 9543, 9544, 9545, 9546, 9547, 9548, 9549, 9550, 9551, 9552, 9553, 9554, 9555, 9556, 9557, 9558, 9559, 9560, 9561, 9562, 9563, 9564, 9565, 9566, 9567, 9568, 9569, 9570, 9571, 9572, 9573, 9574, 9575, 9576, 9577, 9578, 9579, 9580, 9581, 9582, 9583, 9584, 9585, 9586, 9587, 9588, 9589, 9590, 9591, 9592, 9593, 9594, 9595, 9596, 9597, 9598, 9599, 9600, 9601, 9602, 9603, 9604, 9605, 9606, 9607, 9608, 9609, 9610, 9611, 9612, 9613, 9614, 9615, 9616, 9617, 9618, 9619, 9620, 9621, 9622, 9623, 9624, 9625, 9626, 9627, 9628, 9629, 9630, 9631, 9632, 9633, 9634, 9635, 9636, 9637, 9638, 9639, 9640, 9641, 9642, 9643, 9644, 9645, 9646, 9647, 9648, 9649, 9650, 9651, 9652, 9653, 9654, 9655, 9656, 9657, 9658, 9659, 9660, 9661, 9662, 9663, 9664, 9665, 9666, 9667, 9668, 9669, 9670, 9671, 9672, 9673, 9674, 9675, 9676, 9677, 9678, 9679, 9680, 9681, 9682, 9683, 9684, 9685, 9686, 9687, 9688, 9689, 9690, 9691, 9692, 9693, 9694, 9695, 9696, 9697, 9698, 9699, 9700, 9701, 9702, 9703, 9704, 9705, 9706, 9707, 9708, 9709, 9710, 9711, 9712, 9713, 9714, 9715, 9716, 9717, 9718, 9719, 9720, 9721, 9722, 9723, 9724, 9725, 9726, 9727, 9728, 9729, 9730, 9731, 9732, 9733, 9734, 9735, 9736, 9737, 9738, 9739, 9740, 9741, 9742, 9743, 9744, 9745, 9746, 9747, 9748, 9749, 9750, 9751, 9752, 9753, 9754, 9755, 9756, 9757, 9758, 9759, 9760, 9761, 9762, 9763, 9764, 9765, 9766, 9767, 9768, 9769, 9770, 9771, 9772, 9773, 9774, 9775, 9776, 9777, 9778, 9779, 9780, 9781, 9782, 9783, 9784, 9785, 9786, 9787, 9788, 9789, 9790, 9791, 9792, 9793, 9794, 9795, 9796, 9797, 9798, 9799, 9800, 9801, 9802, 9803, 9804, 9805, 9806, 9807, 9808, 9809, 9810, 9811, 9812, 9813, 9814, 9815, 9816, 9817, 9818, 9819, 9820, 9821, 9822, 9823, 9824, 9825, 9826, 9827, 9828, 9829, 9830, 9831, 9832, 9833, 9834, 9835, 9836, 9837, 9838, 9839, 9840, 9841, 9842, 9843, 9844, 9845, 9846, 9847, 9848, 9849, 9850, 9851, 9852, 9853, 9854, 9855, 9856, 9857, 9858, 9859, 9860, 9861, 9862, 9863, 9864, 9865, 9866, 9867, 9868, 9869, 9870, 9871, 9872, 9873, 9874, 9875, 9876, 9877, 9878, 9879, 9880, 9881, 9882, 9883, 9884, 9885, 9886, 9887, 9888, 9889, 9890, 9891, 9892, 9893, 9894, 9895, 9896, 9897, 9898, 9899, 9900, 9901, 9902, 9903, 9904, 9905, 9906, 9907, 9908, 9909, 9910, 9911, 9912, 9913, 9914, 9915, 9916, 9917, 9918, 9919, 9920, 9921, 9922, 9923, 9924, 9925, 9926, 9927, 9928, 9929, 9930, 9931, 9932, 9933, 9934, 9935, 9936, 9937, 9938, 9939, 9940, 9941, 9942, 9943, 9944, 9945, 9946, 9947, 9948, 9949, 9950, 9951, 9952, 9953, 9954, 9955, 9956, 9957, 9958, 9959, 9960, 9961, 9962, 9963, 9964, 9965, 9966, 9967, 9968, 9969, 9970, 9971, 9972, 9973, 9974, 9975, 9976, 9977, 9978, 9979, 9980, 9981, 9982, 9983, 9984, 9985, 9986, 9987, 9988, 9989, 9990, 9991, 9992, 9993, 9994, 9995, 9996, 9997, 9998, 9999, 10000.

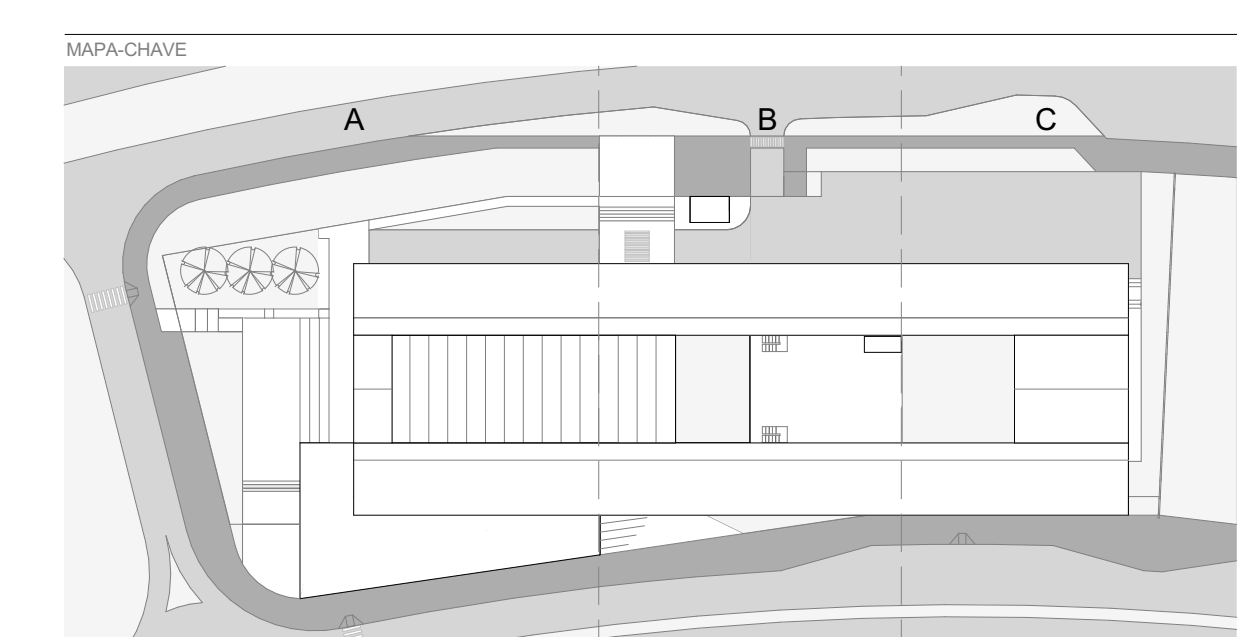

RESPONSÁVEL TÉCNICO PELO PROJETO
EDER RODRIGUES DE ALENCAR
CAU 40033

ETAPA	OBJETO
PROJETO EXECUTIVO	ESQUADRIAS - CX-04 / CX-05
DATA	ESCALA
DEZ 2019	INDICADA